

SCHEMATIC DESIGN PRESENTATION
HENLEY MIDDLE SCHOOL AUXILIARY GYM ADDITION

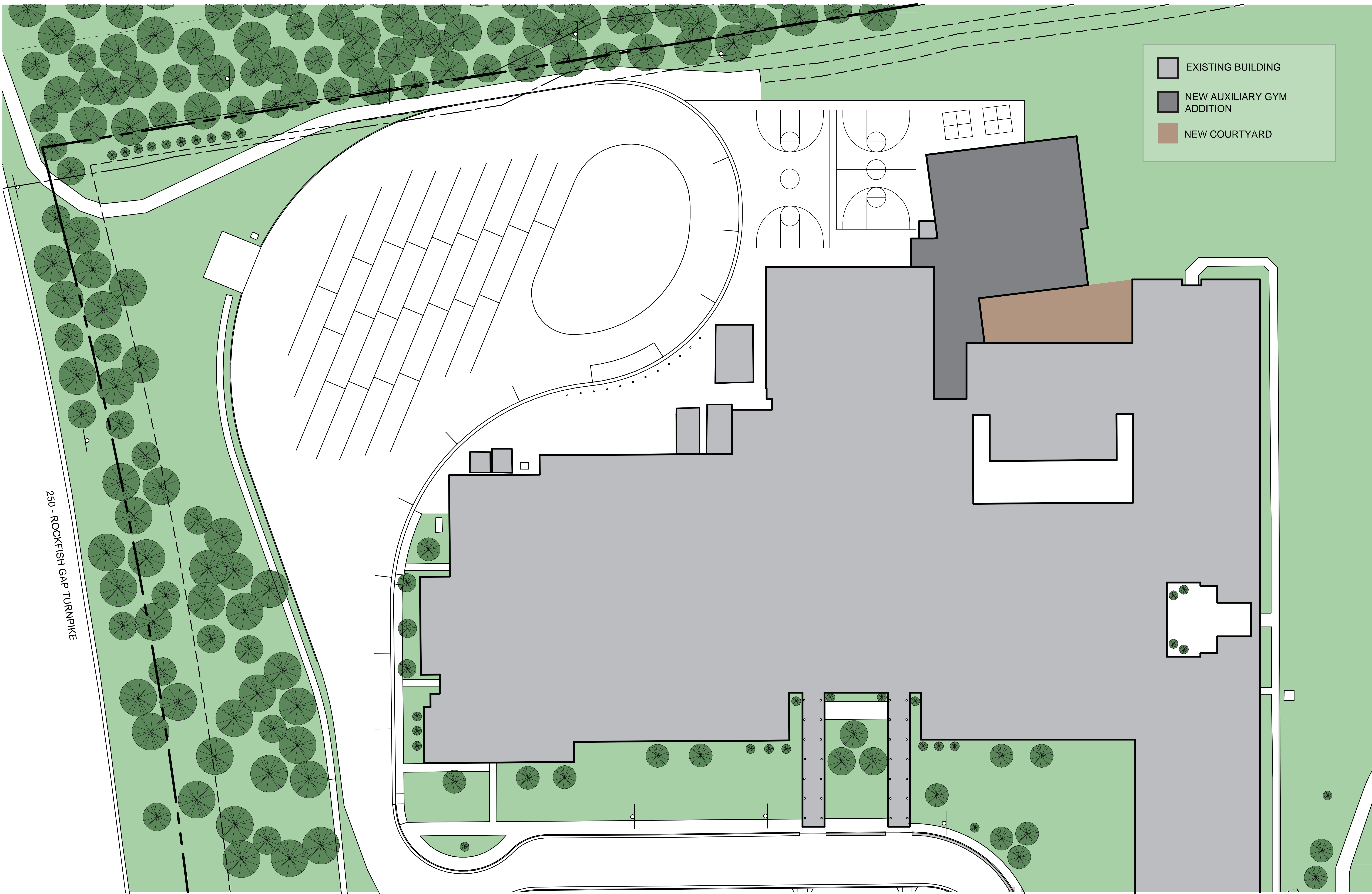

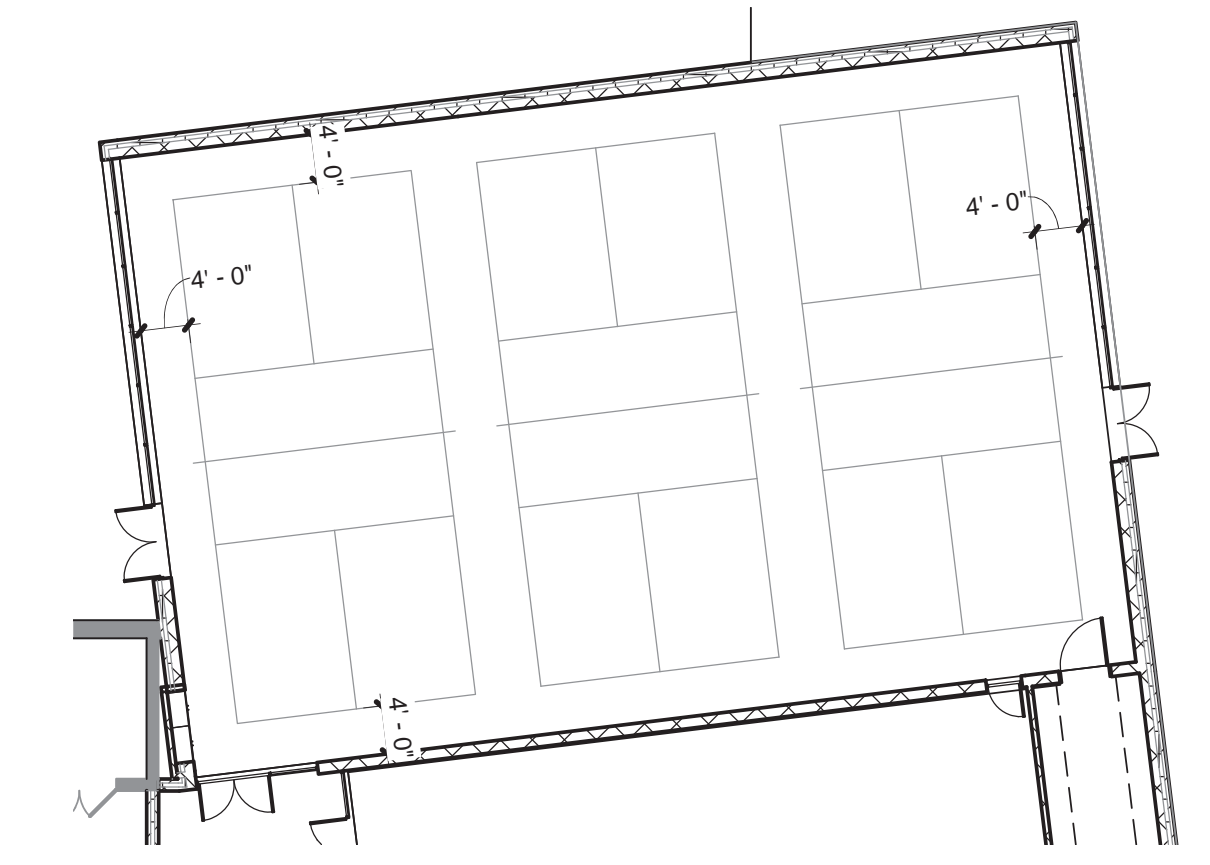

2 MP ROOM: (3) PICKLE BALL COURTS
1/16" = 1'-0"

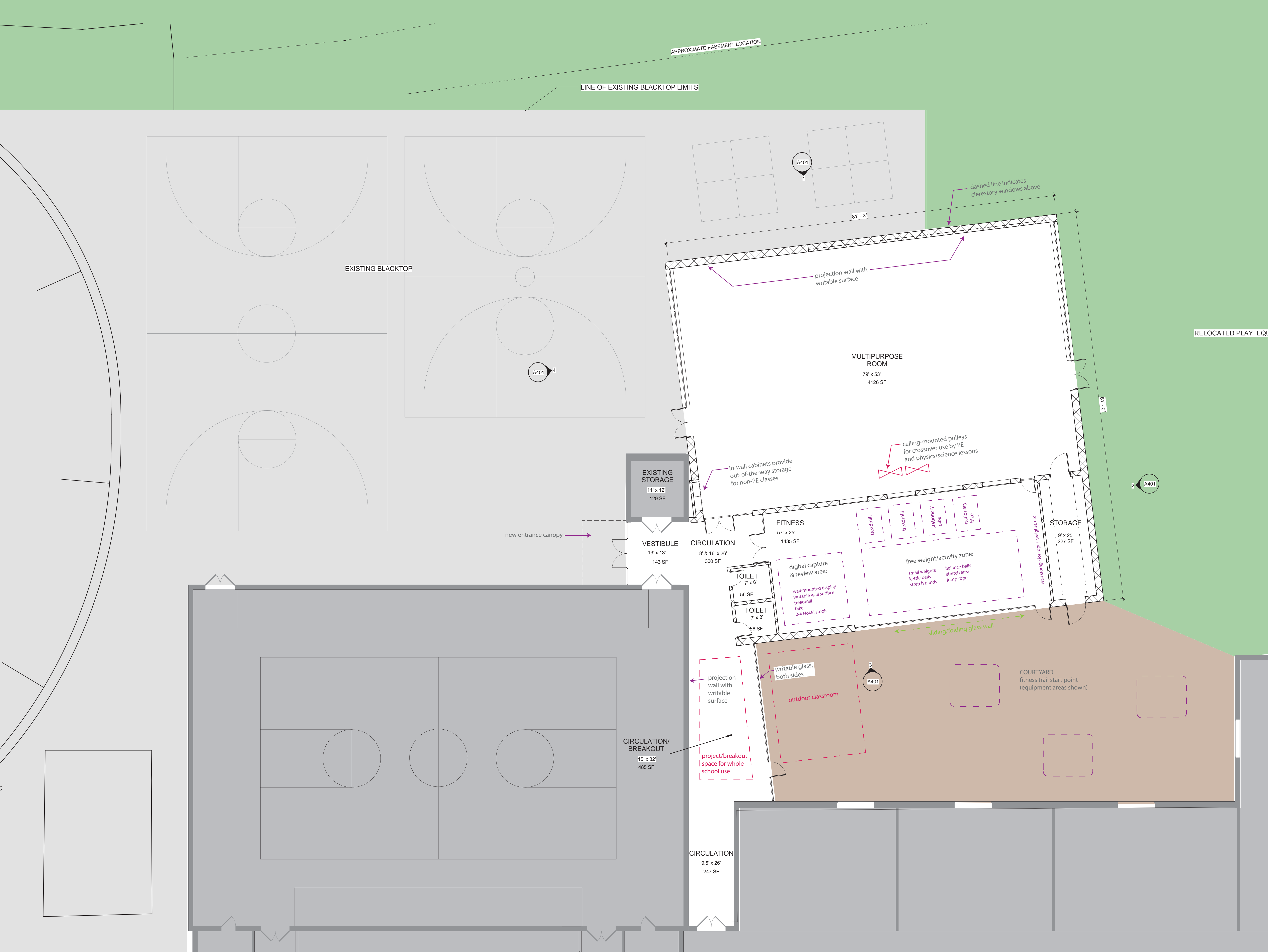
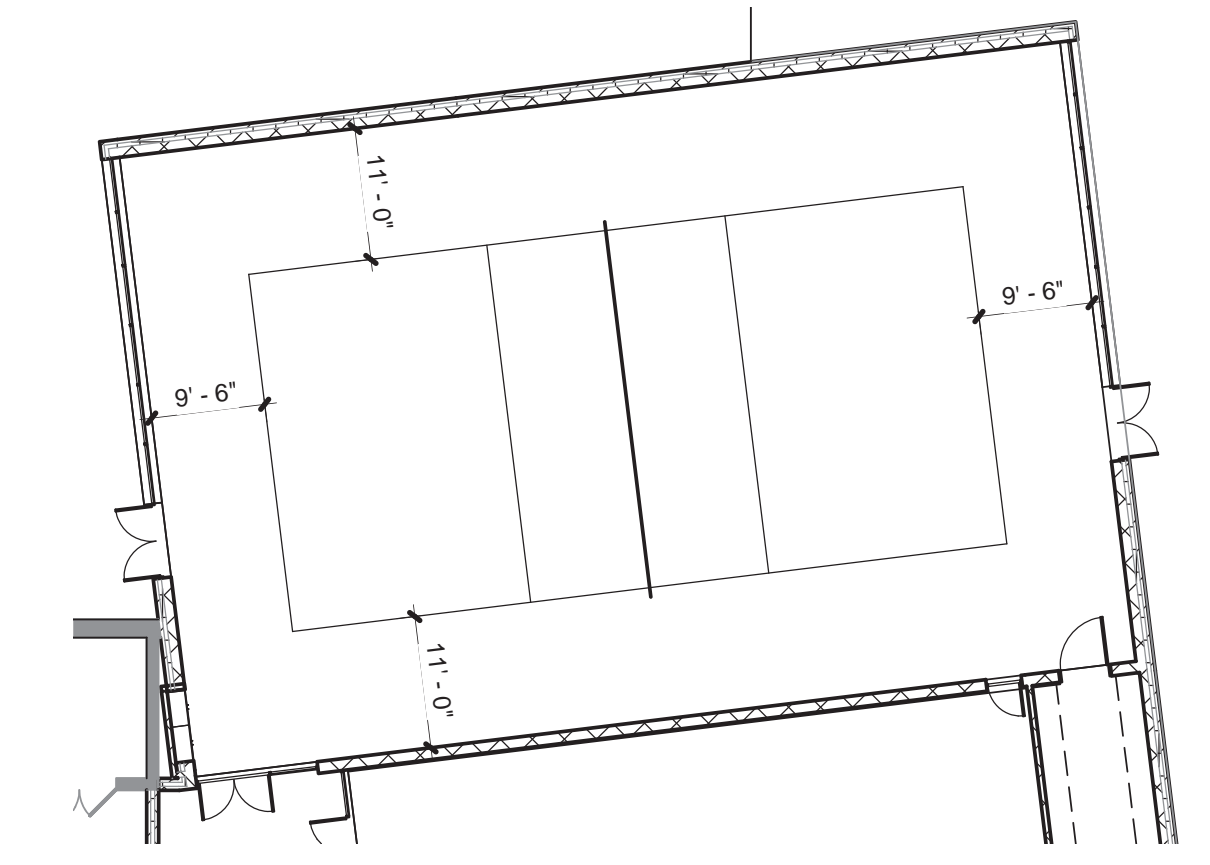

3 MP ROOM: (1) VOLLEYBALL COURT
1/16" = 1'-0"

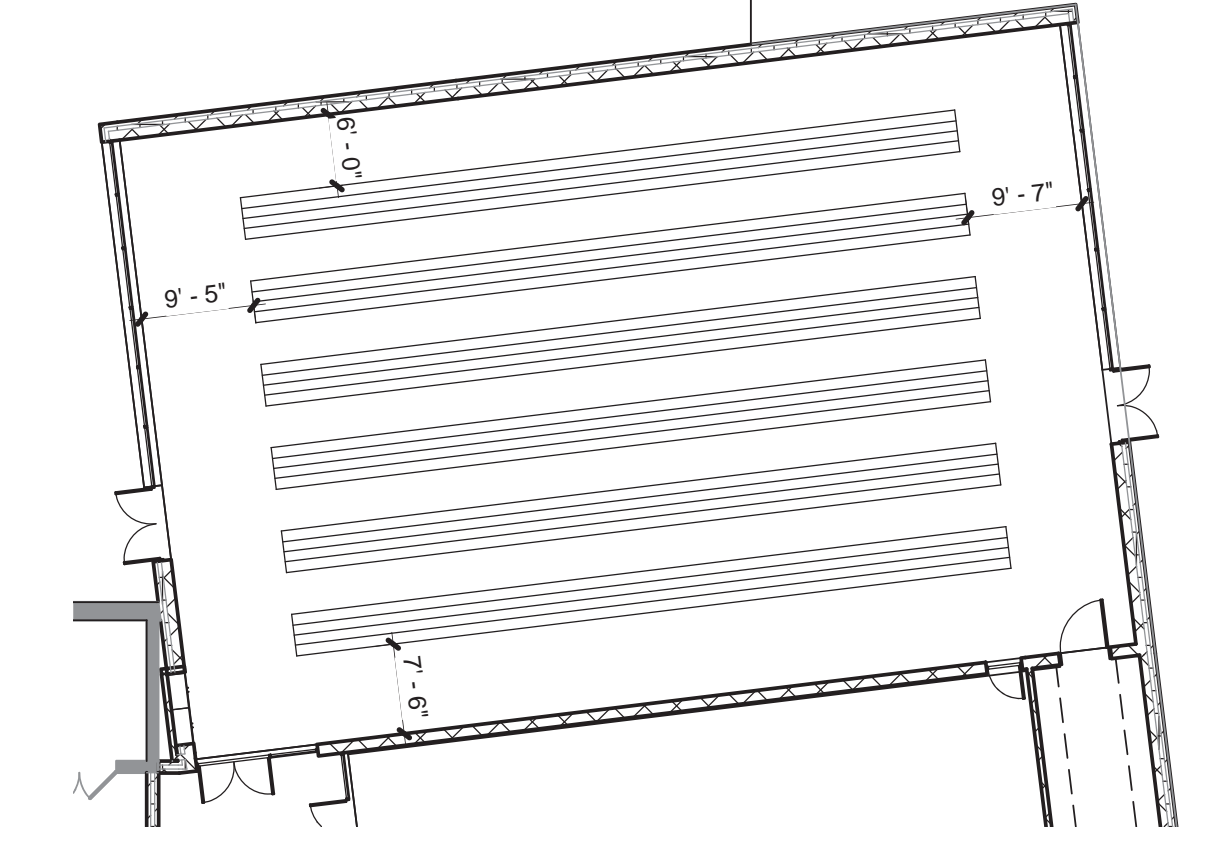

4 MP ROOM: (6) 20 YD SPRINT LANES
1/16" = 1'-0"

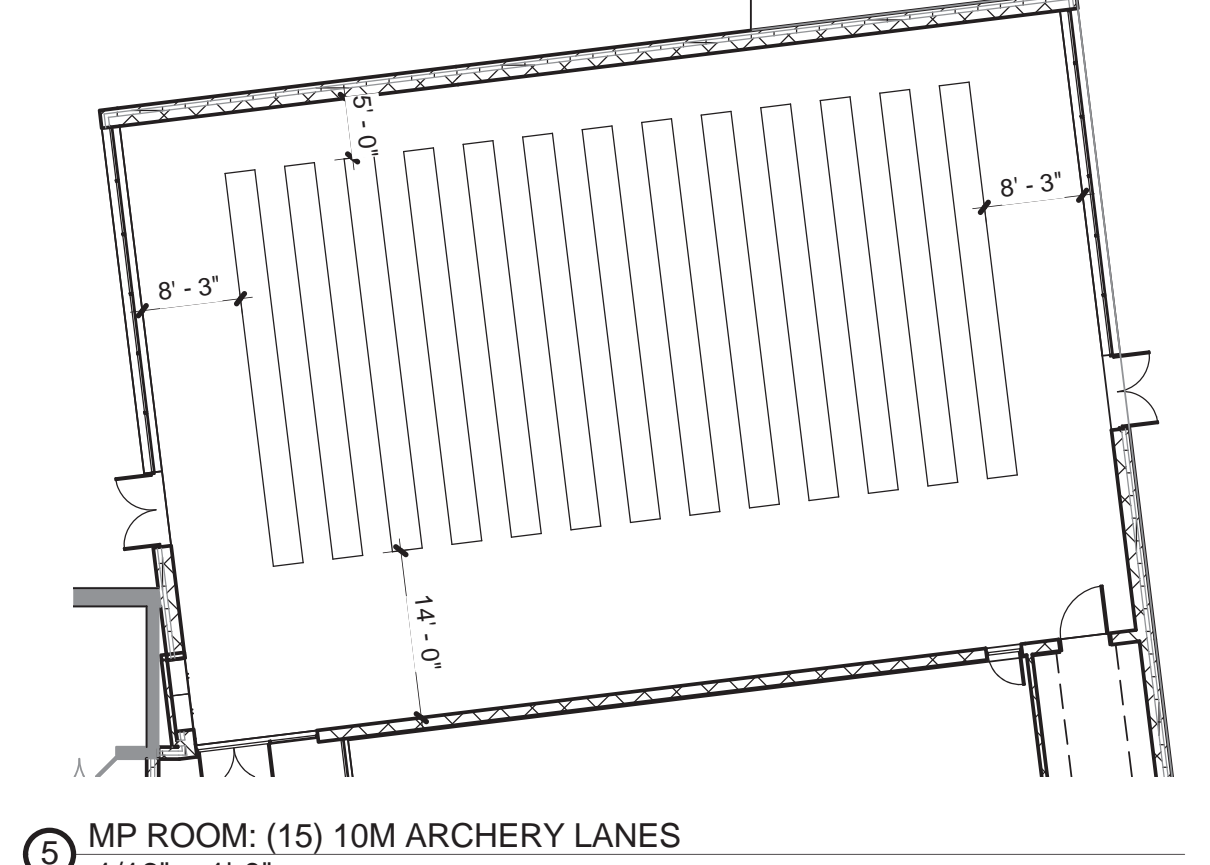

5 MP ROOM: (15) 10M ARCHERY LANES
1/16" = 1'-0"

OPTION 1E
7,400 SF
GROSS



SCHEMATIC FLOOR PLAN
HENLEY MIDDLE SCHOOL AUXILIARY GYM ADDITION



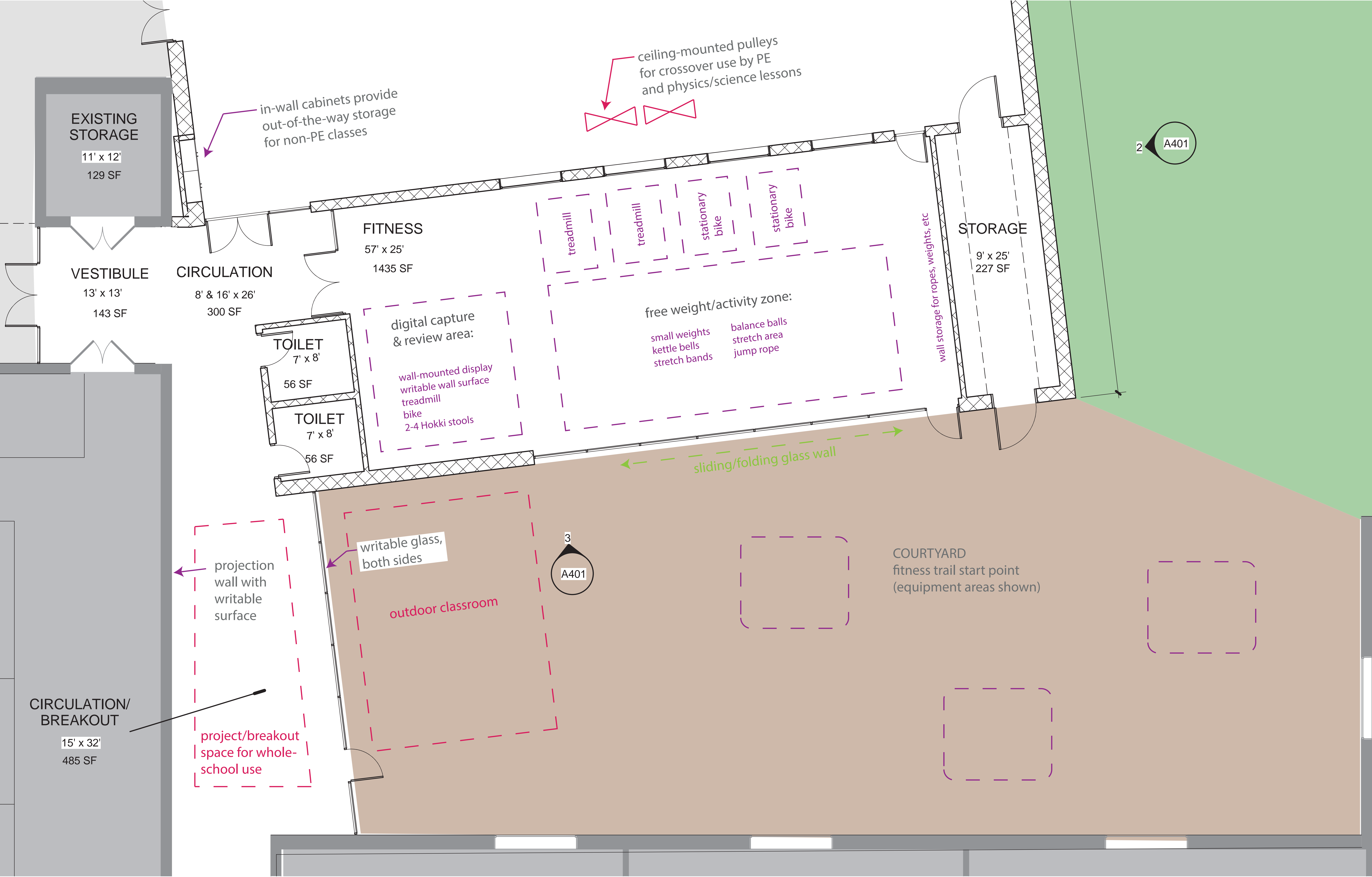

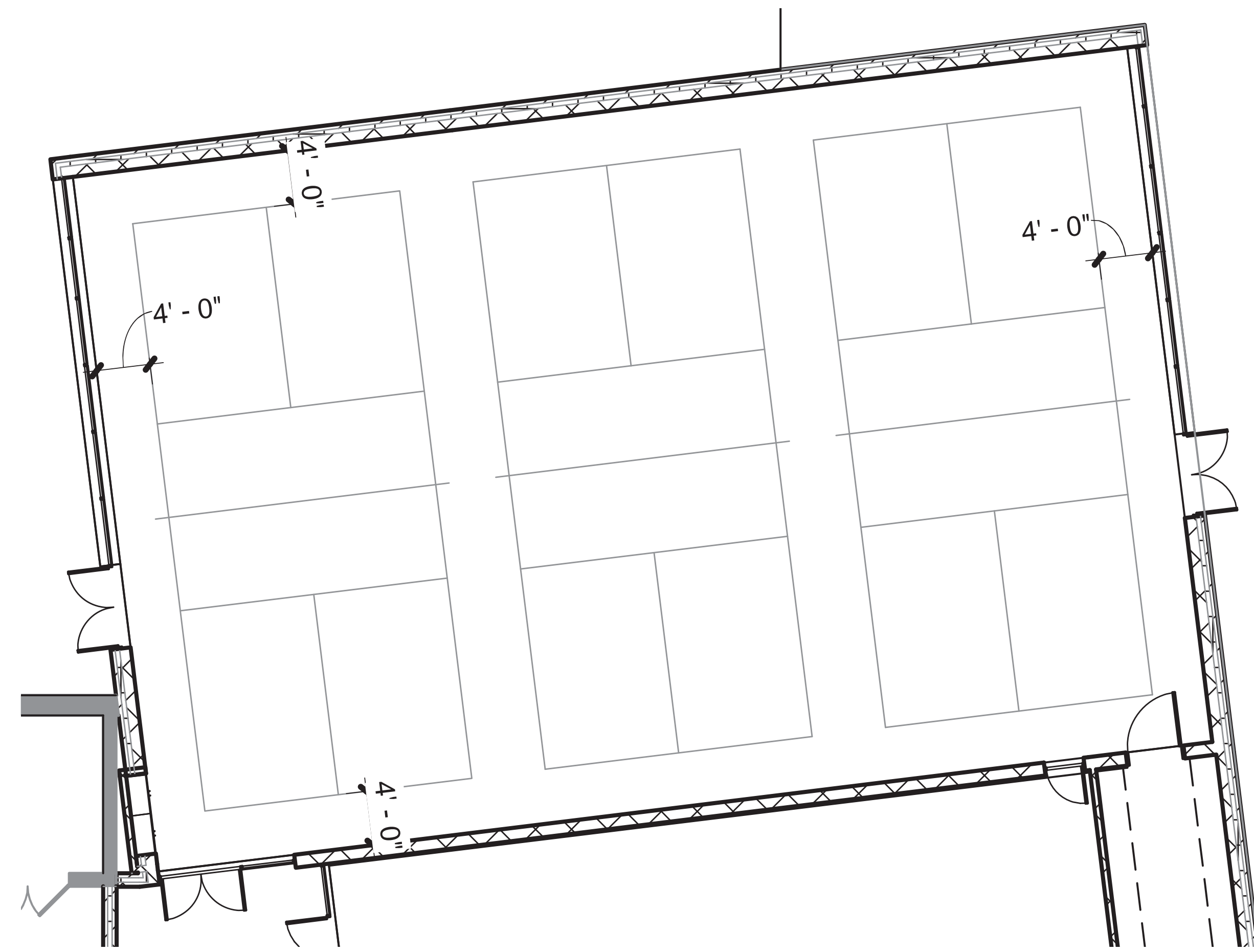

② MP ROOM: (3) PICKLE BALL COURTS

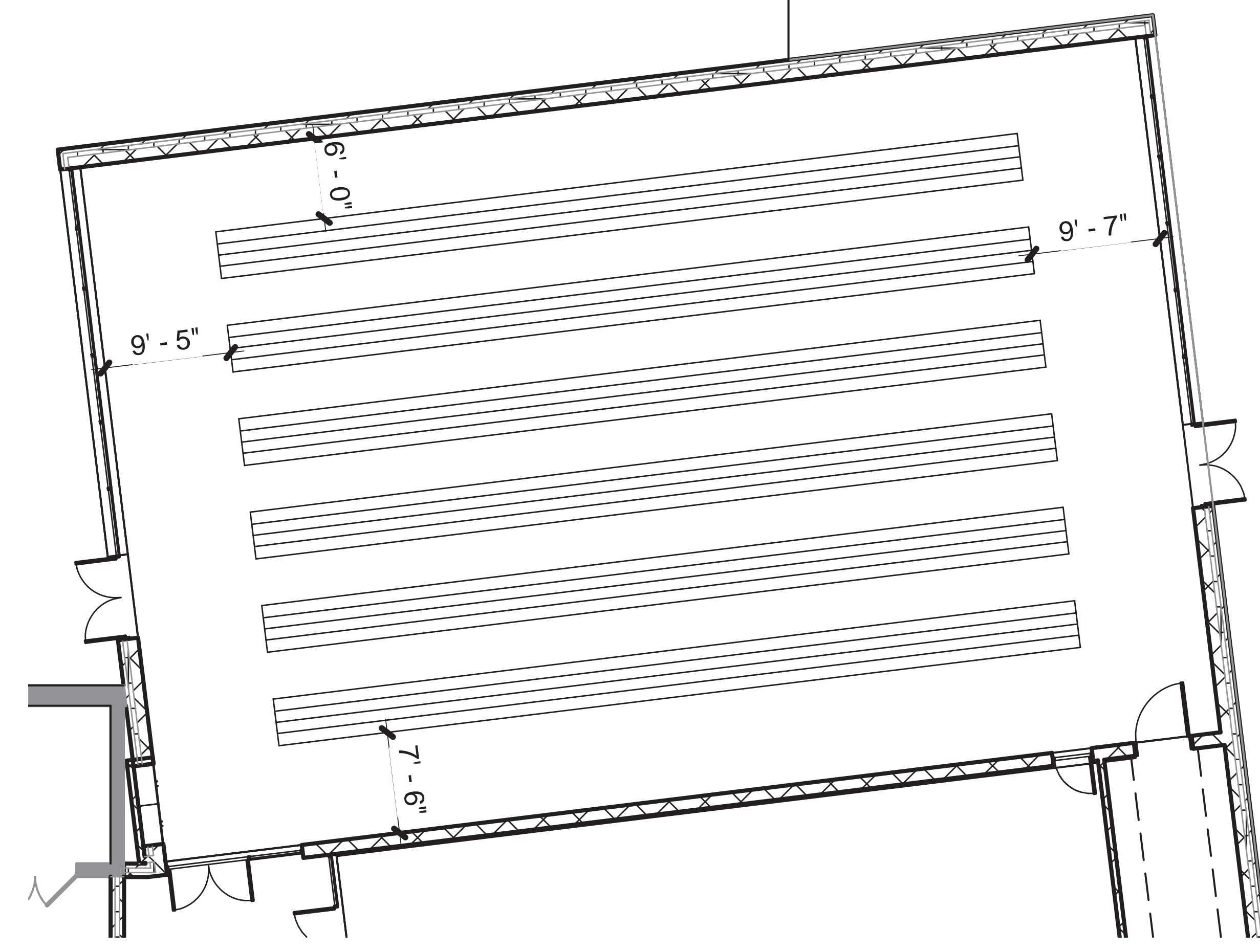

④ MP ROOM: (6) 20 YD SPRINT LANES

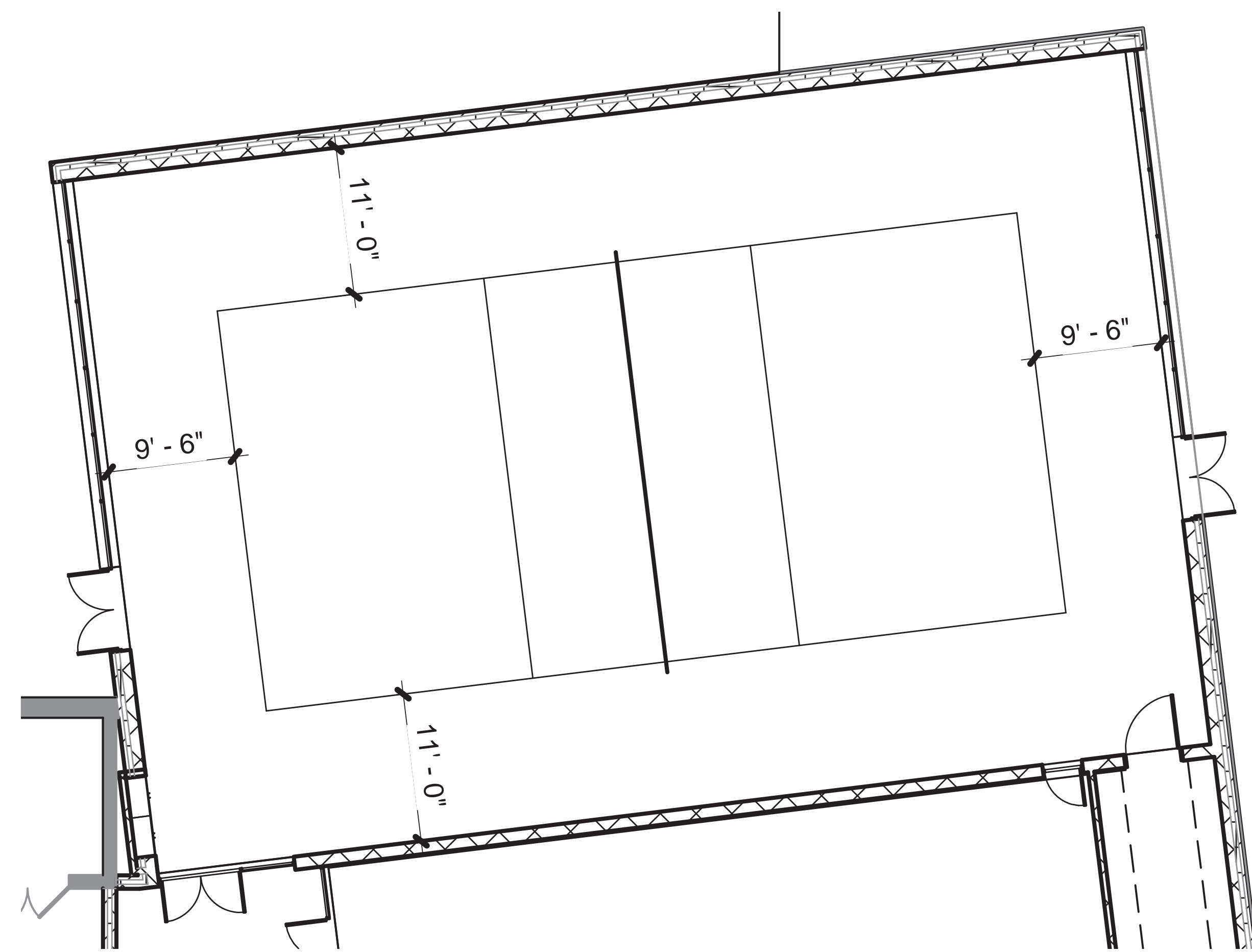

③ MP ROOM: (1) VOLLEYBALL COURT

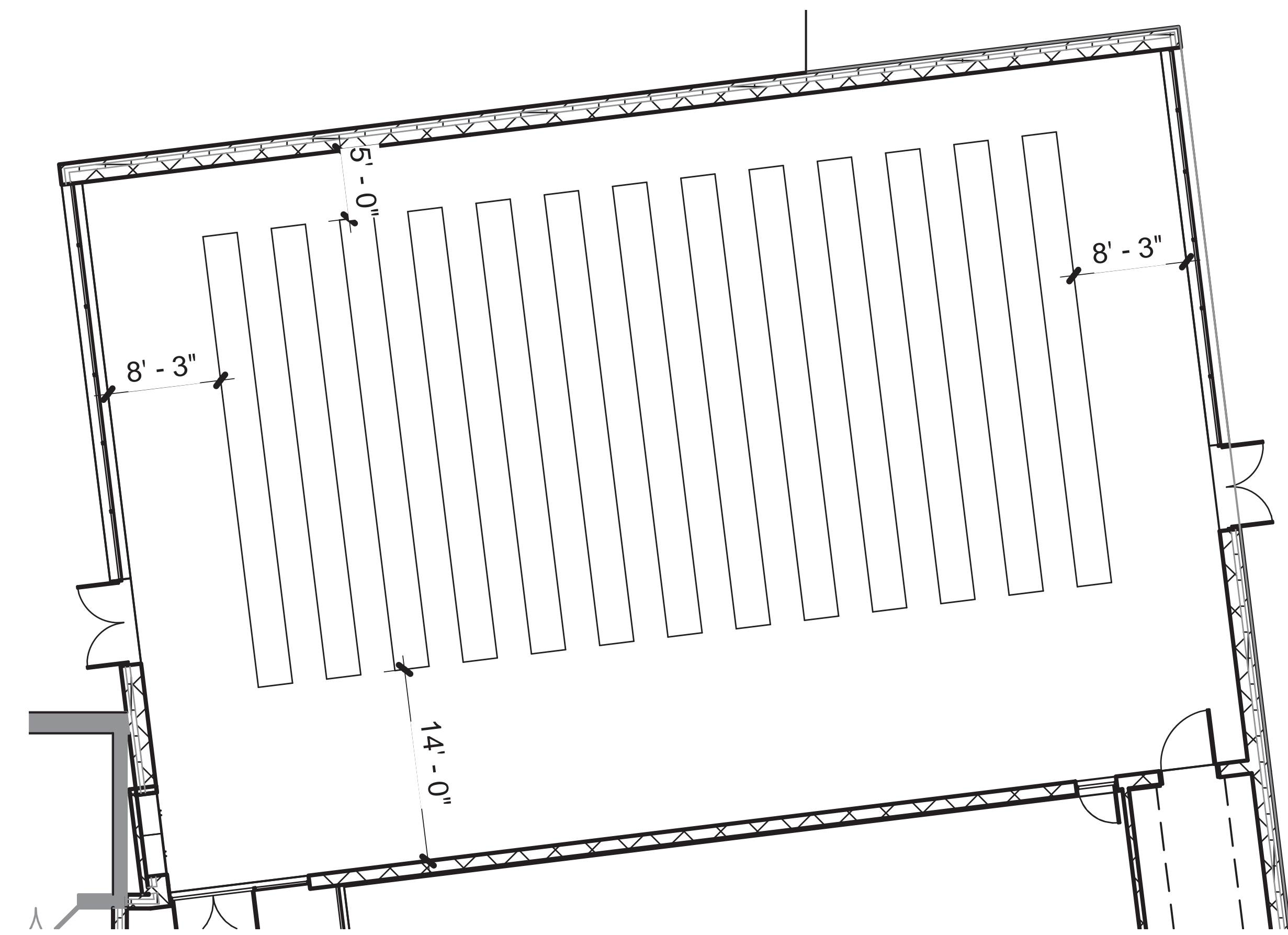

⑤ MP ROOM: (15) 10M ARCHERY LANES





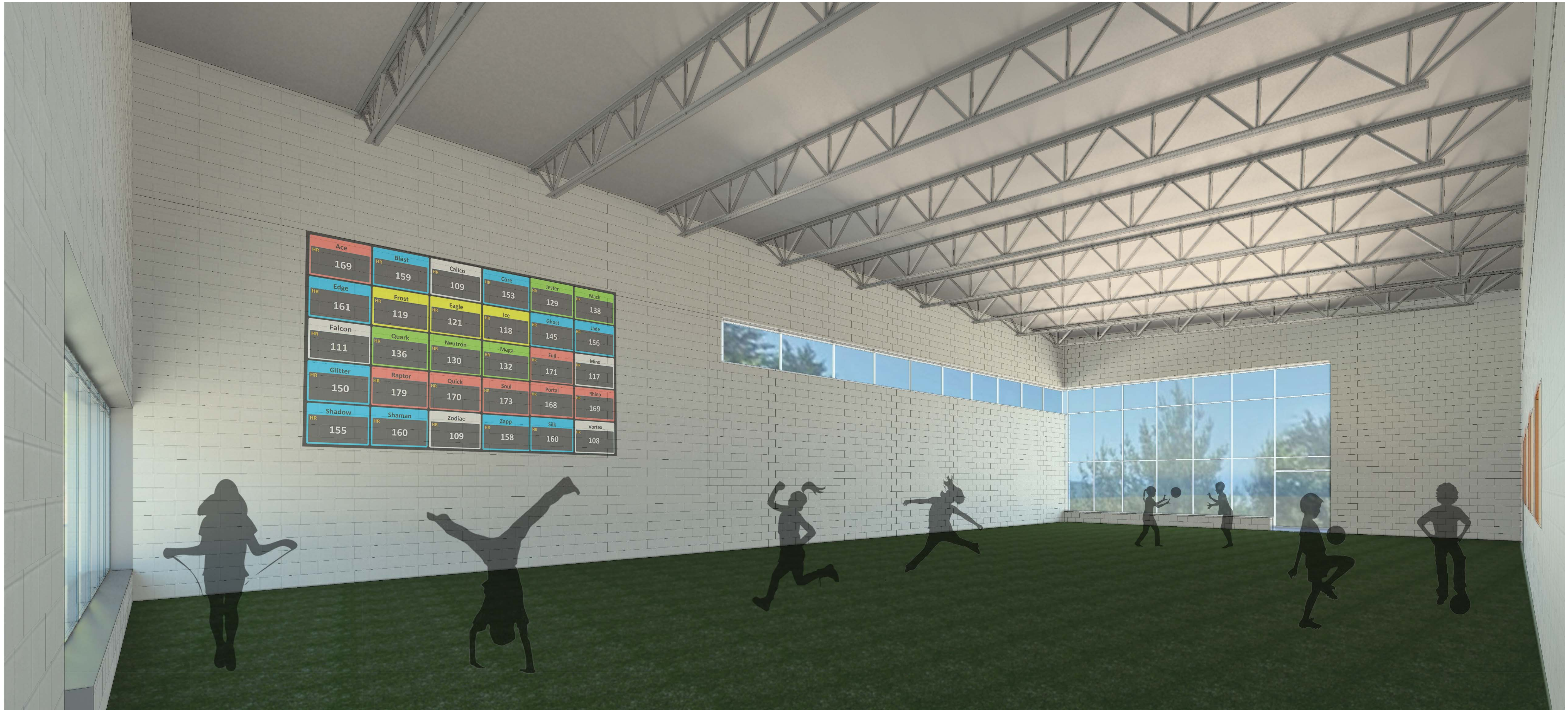





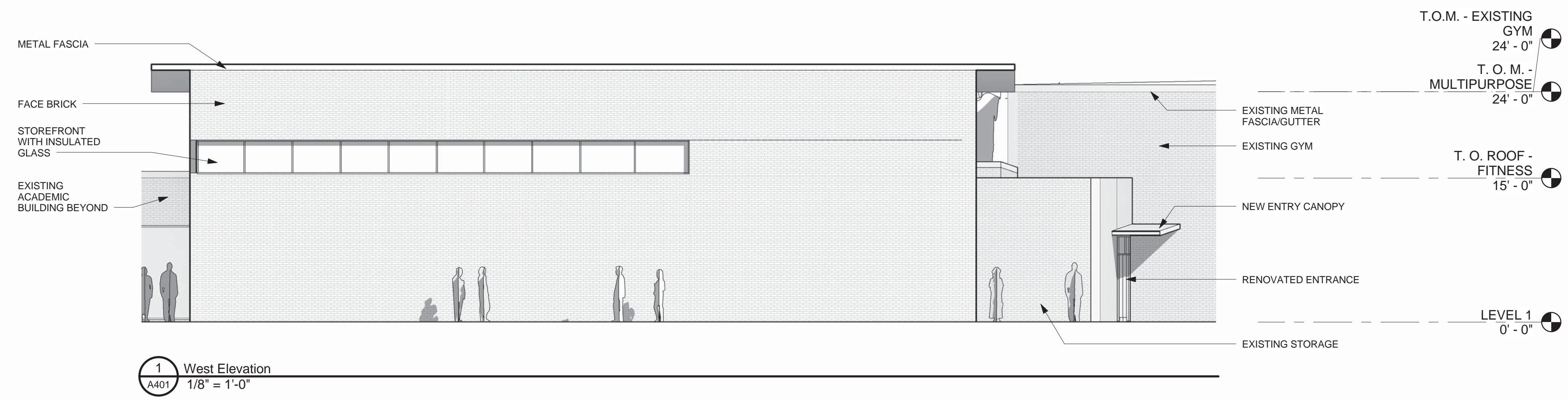

1 West Elevation
A401 1/8" = 1'-0"

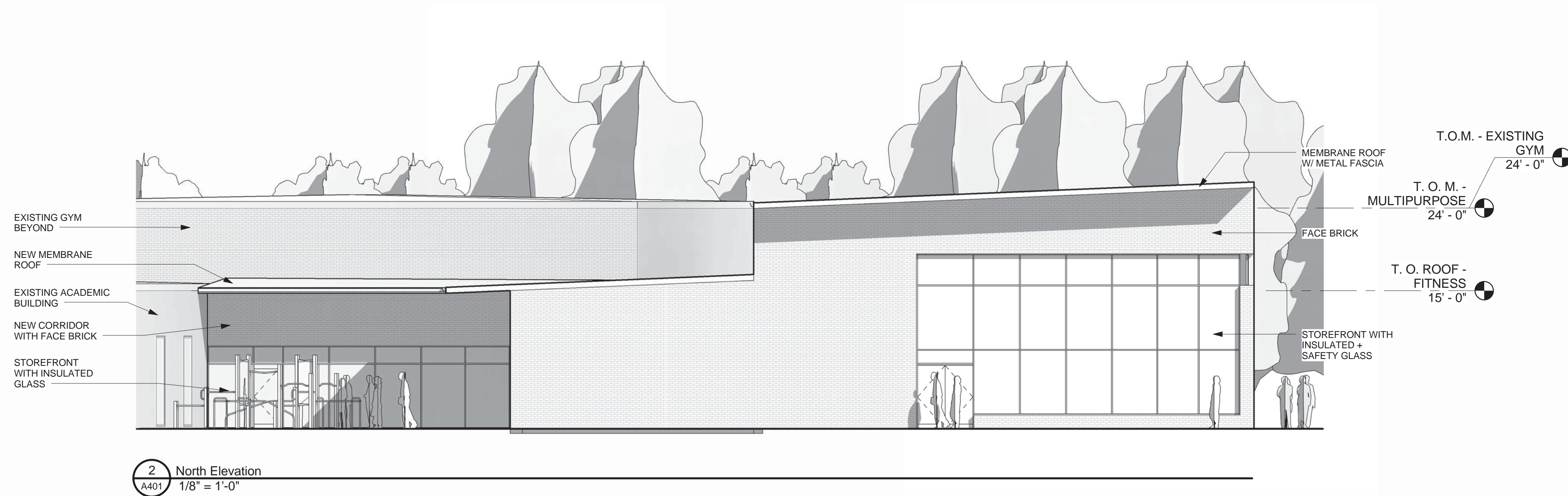

2 North Elevation
A401 1/8" = 1'-0"

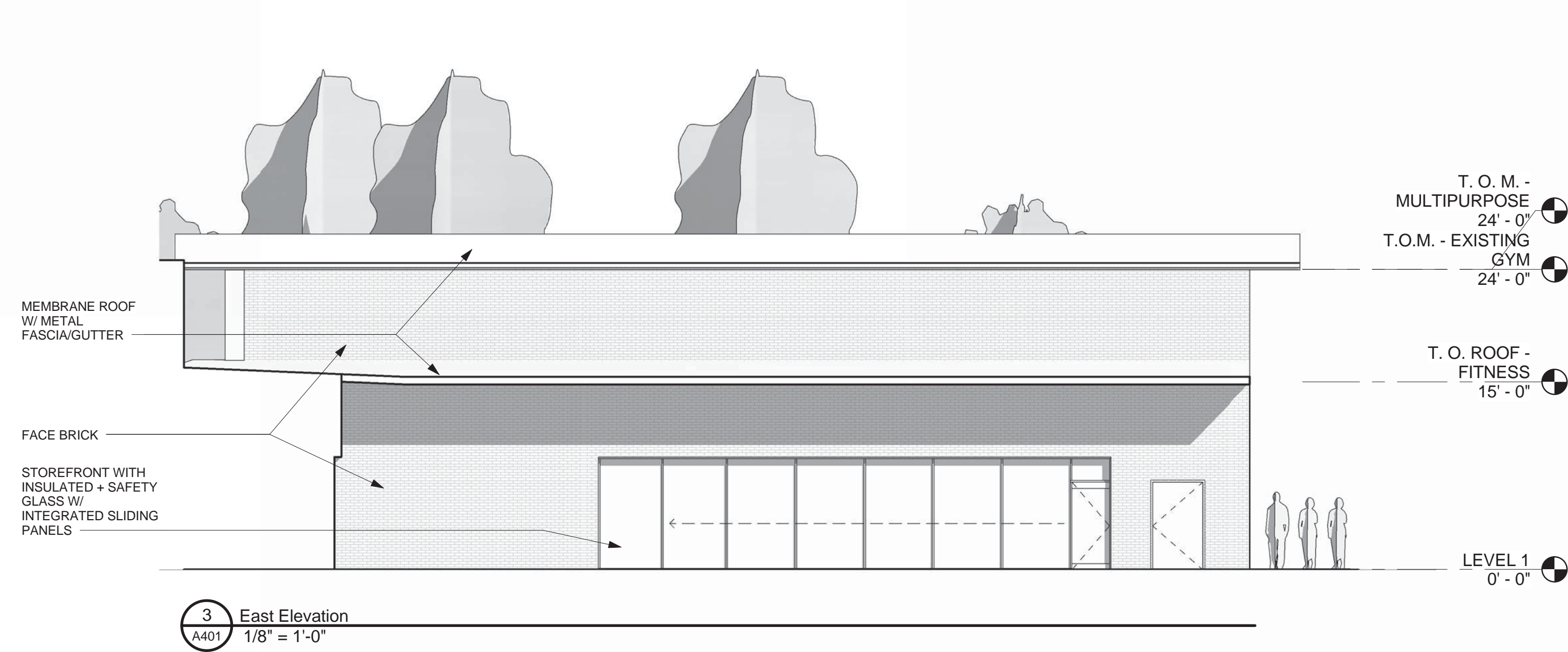

3 East Elevation
A401 1/8" = 1'-0"

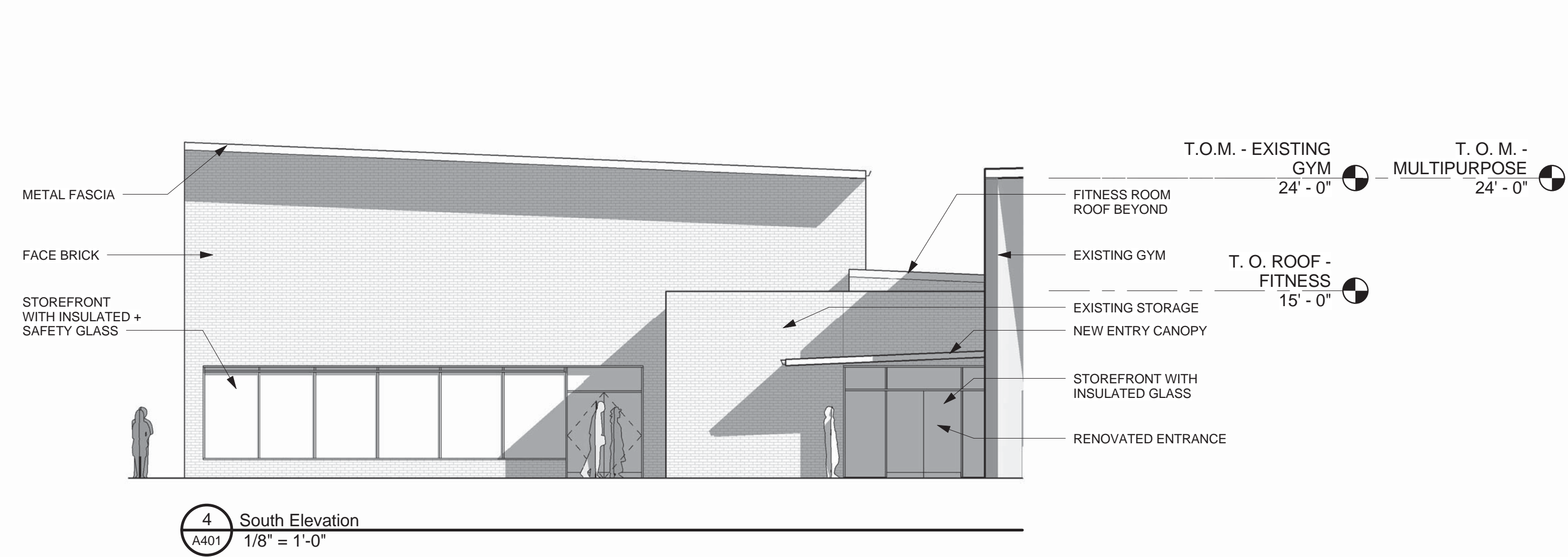

4 South Elevation
A401 1/8" = 1'-0"